



SJ12 SJ16

SELF PROPELLED VERTICAL MAST LIFTS

Skyjack's SJ12 and SJ16 self propelled vertical mast lifts provide a compact footprint and superior maneuverability. When operating in tight work spaces, a high degree steer angle allows for superior functionality and flexibility by offering zero inside turning radius. Both models feature a 0.41 m traversing platform, providing increased access and the ability to reach over potential obstacles.

A unique slide away platform provides easy access to components, when raised or in the stowed position.



SKYJACK™

SELF PROPELLED VERTICAL MAST LIFTS

SPECIFICATIONS

SJ 12

SJ 16

AS/NZS 1418.10:2011

A Work Height	5.65 m	6.75 m
B Raised Platform Height	3.65 m	4.75 m
C Lowered Platform Height	0.45 m	0.45 m
D Overall Width	0.76 m	0.76 m
E Overall Length	1.37 m	1.37 m
F Stowed Height	1.79 m	1.79 m
G Platform Width (Inside Dimension)	0.69 m	0.69 m
H Platform Length (Outside Dimension)	0.93 m	0.93 m
Ground Clearance (Stowed)	5.33 cm	5.33 cm
Ground Clearance (Raised)	1.6 cm	1.6 cm
Weight	782 kg	966 kg
Local Floor Load (With Rated Load)	696 kPa	827 kPa
Local Floor Load (No Load)	552 kPa	634 kPa
Gradeability	30%	30%
Turning Radius (Inside)	0	0
Turning Radius (Outside)	1.4 m	1.4 m
Drive Speed (Stowed)	4.0 km/h	4.0 km/h
Drive Speed (Raised)	0.8 km/h	0.8 km/h
Maximum Drive Height	Full Height	Full Height
Capacity (Overall)	227 kg	227 kg
Maximum # of Persons	2	2

STANDARD FEATURES

- Drivable at full height
- Variable speed, front two wheel hydraulic drive
- Zero inside turning radius
- Wet disc SAHR brakes
- Proportional controls
- 0.41 m traversing platform
- 24V DC power source
- Low voltage battery protection
- 30% gradeability
- Solid rubber, non-marking tyres
- Pothole protection system
- Wiring for AC outlet at platform
- 12.5 m/s wind rating (SJ12 only)
- Tilt alarm with drive & lift cut-out
- All motion audible alarm
- Lanyard attachment points
- Operator horn
- Lift rings/tie downs
- Full height spring hinged gate
- Relay based control system
- Colour coded and numbered wiring system

OPTIONS‡

- Dual flashing lights
- Light duty pipe rack/steel stud rack
- Tool tray
- Bio oil

‡ Capacities, and machine weights may differ when options are added.

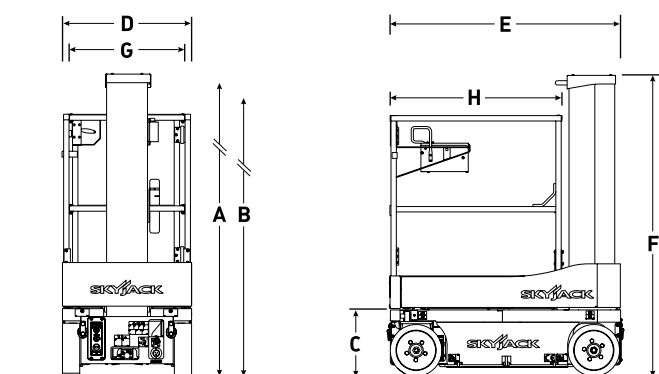

09 947 4247

021 500 486

sales@elevatedaccess.co.nz

www.elevatedaccess.co.nz

This brochure is for illustrative purpose only and based on the latest information at the time of printing. Skyjack Inc. reserves the right to make changes at any time, without notice, to specifications, standard and optional equipment. Consult the Operating Maintenance and Parts Manuals for proper procedures. AS marked platforms are in conformance to Standard AS/NZS 1418.10:2011.



SKYJACK™

AU/NZ/04/2013