

# MHP13AT/14AT

## TRAILER MOUNTED BOOM LIFTS



- Safe and stable working height of up to 13.5m
- Heavy duty trailer mounted articulated boom lift
- Robust steel platform with two man capacity
- Easy to use outrigger/boom safety interlocks
- Ideal for a wide range of applications

 **snorkel**  
[www.elevatedaccess.co.nz](http://www.elevatedaccess.co.nz)

# TRAILER MOUNTED BOOM LIFTS MHP13AT/14AT

DIMENSIONS	MHP13AT	MHP14AT
Max. working height	12.9m	13.5m
Max. platform height (A)	10.9m	11.5m
Horizontal outreach	6.4m	6.4m
Platform size	1.15m x 0.70m	1.15m x 0.70m
Overall width (outriggers extended)	3.6m	3.6m
Overall width (outriggers retracted) (B)	1.6m	1.6m
Overall length (C)	4.9m	4.9m
Transport height (D)	2m	2m

## PERFORMANCE

Platform capacity	215kg	215kg
Max. wind speed	12.5m/sec	12.5m/sec
Levelling	Hydraulic (master/slave)	Hydraulic(master/slave)
Turntable rotation	540° non-continuous	540° non-continuous
Tyres	185 R14 102/100P	185 R14 102/100P
Brakes	Hydraulic over-run non free reversing	
Insulation rating	Nil	Nil
Trailer tongue weight	80kg	80kg

## POWER

Power source	Honda petrol	Honda petrol
--------------	--------------	--------------

## WEIGHT

Gross weight	1,460kg	1,460kg
--------------	---------	---------

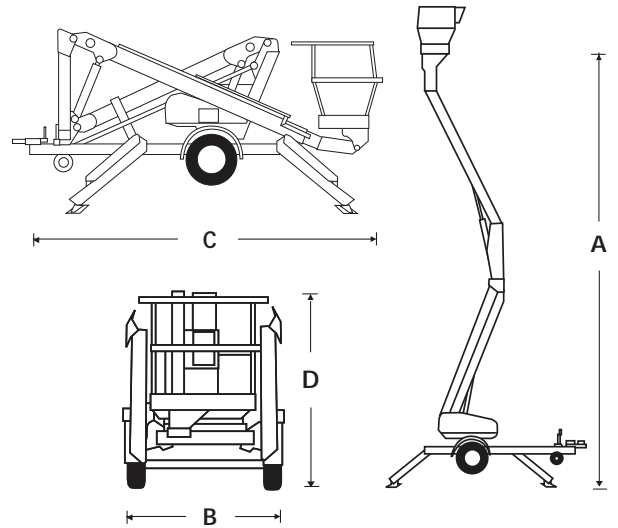

## STANDARD FEATURES

- Heavy duty tow coupling
- Hydraulic stabilisers
- Solid platform
- Two person capacity
- Heavy duty jockey wheel
- Hydraulic disc brakes
- Reliable petrol engine
- Outrigger/boom safety interlocks
- LED taillights
- Manual basket rotator

## OPTIONS

- Automatic stabilisers
- Custom colours
- Platform work lights
- Air line to platform
- Flashing light
- Height lockout (MHP14AT only)
- Lifting lugs
- Spare wheel
- 240V 110V outlet in platform
- Battery isolate switch
- Platform foot switch
- Diesel and bi-energy options

## WORKING ENVELOPE

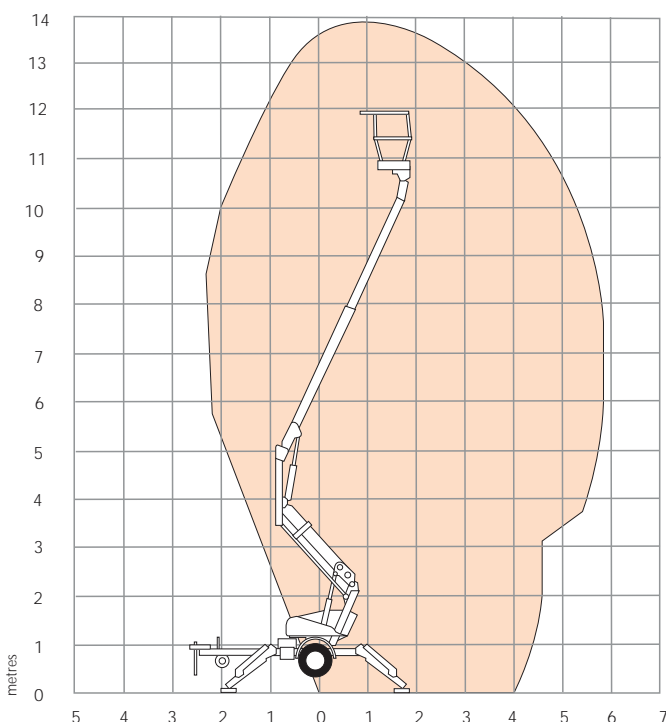

0800 222 111  
021 500 486  
sales@elevatedaccess.co.nz  
www.elevatedaccess.co.nz