

LE SERIES

LARGE ELECTRIC SCISSOR LIFTS



Performance

Platform Height—Elevated	
3369LE	10.06 m
M3369LE	10.06 m
4069LE	12.19 m
M4069LE	12.19 m
Platform Capacity	
3369LE	450 kg
M3369LE	450 kg
4069LE	360 kg
M4069LE	360 kg
Capacity on Platform Extension	
	120 kg
Lift/Lower Time	
3369LE	38/42 sec
M3369LE	38/42 sec
4069LE	54/50 sec
M4069LE	54/50 sec
Maximum Drive Height	
3369LE	Full Height
M3369LE	Full Height
4069LE	9.14 m
M4069LE	Full Height
Weight*	
3369LE	4,600 kg
M3369LE	5,250 kg
4069LE	5,300 kg
M4069LE	5,700 kg
Drive Speed	
Elevated	0.64 kmph
Lowered	4.8 kmph
Gradeability	
2WD (3369 LE, 4069LE)	35%
4WD (M3369LE, M4069LE)	45%
Turning Radius	
Inside	2.29 m
Outside	4.90 m

Standard Specifications

Tyres

- Standard 240/55-17.5 Foam-Filled Non-Marking Tyres

Brakes

- Spring Applied Hydraulically Released Discs

Power Source

Batteries	8 x 6V, 370 amp-hr
Charger	20 Amp, Automatic SCR Charger
Electric Pump Motor	Series Wound
Drive Motors	Two 5.5 hp Shunt Wound
Generator Set (M models only)	
45 Amp Kubota	4.47 kW
Engine Fuel Tank Capacity	15.14 L

Hydraulic System

Capacity	32.18 L
Pump	Single Section Gear Pump



Standard Features

- 1.65 x 2.92 m Work Platform
- Full Time ATC—JLG Automatic Traction Control System
- Oscillating Axle
- Proportional Direct DC Electric Drive
- Proportional Lift Up
- 8 x 6V, 370 amp-hr Batteries
- 0.90 m Roll-Out Deck Extension
- On-Board Diagnostics with Common JLG Analyzer
- Fold-Down Hand Rails
- Moveable, Removable Platform Console Box
- 20 Amp Automatic, SCR Battery Charger
- Battery Charge Indicator in Platform
- 3 Degree Tilt Indicator Light and Alarm
- All Motion Alarm
- Manual Descent
- LSS
- Flashing Amber Beacon
- Tie Down Lugs
- Hourmeter
- Horn

Accessories & Options

- AC Outlet to Platform incl ELCB
- Wheel Chocks
- Squawker / White Noise Motion Alarm
- Platform Worklights

LE SERIES

LARGE ELECTRIC SCISSOR LIFTS

JLG
reachingout®



Dimensions

All dimensions are approximate.

3369LE

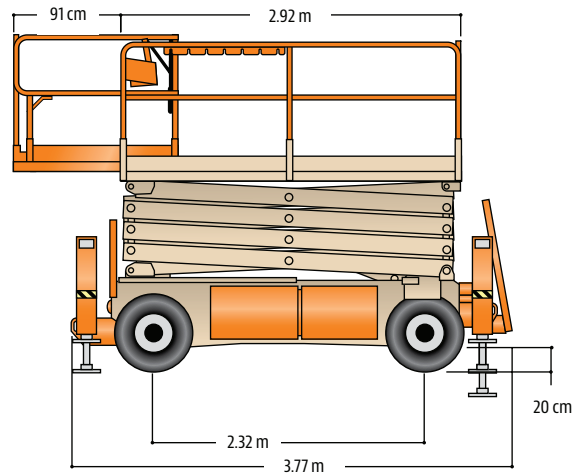
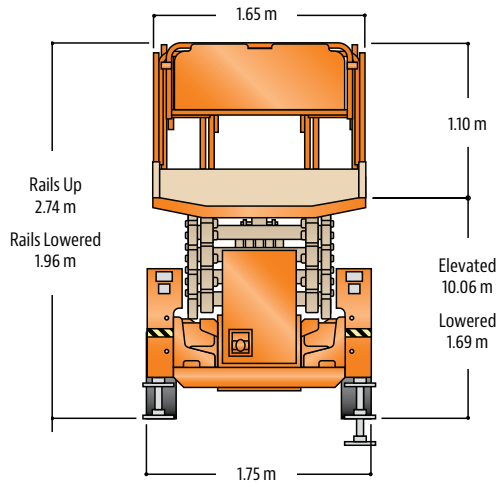

4069LE

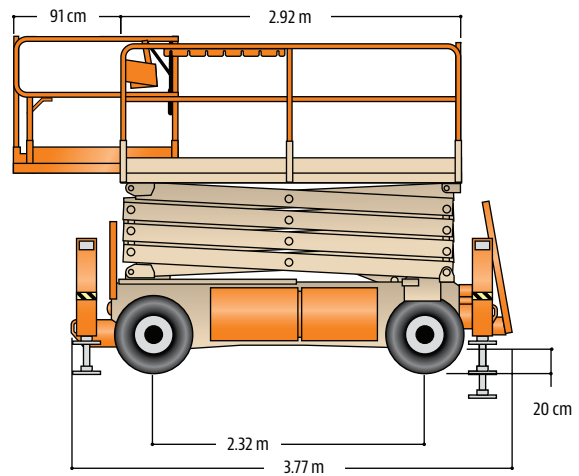
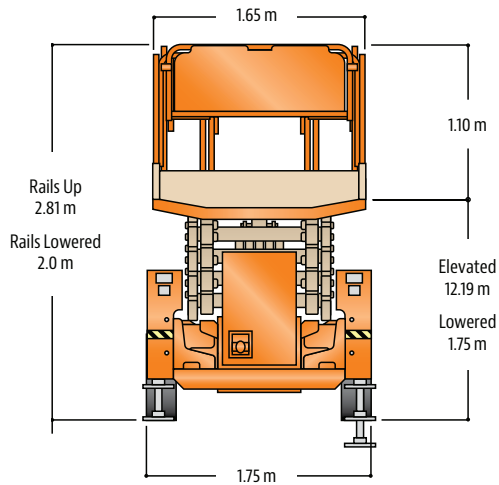

0800 222 111
021 500 486

sales@elevatedaccess.co.nz
www.elevatedaccess.co.nz

The JLG "1 & 5" Warranty

JLG Industries, Inc. backs its products with its exclusive "1 & 5" Warranty. We provide coverage on all products for one (1) full year and cover all specified major structural components for five (5) years. Due to continuous product improvements, we reserve the right to make specification and/or equipment changes without prior notification. This machine meets or exceeds AS/NZS 1418.10 2011 as originally manufactured for intended applications.