



# SJ9241/50 RT

## ROUGH TERRAIN SCISSORS

### STANDARD FEATURES

- Axle based 4WD system
- "Detroit Locker" type rear differential and limited slip front differential
- Diesel engine on roll out tray
- 1.52 m dual powered extension decks
- Disc brake system on rear axle
- Independent/Auto leveling outriggers
- 25% gradeability
- Wiring for AC outlet on platform
- Tilt alarm with drive & lift cut-out
- All motion audible alarm
- Overload sensing system
- Lowering warning system
- Lanyard attachment points
- Tie down/lift lugs
- Operator horn
- Flashing light
- Fold down hinged railing system
- Half height spring hinged gates on both sides
- Relay based control system
- Colour coded and numbered wiring system
- 10 x 16.5 grip lug foam-filled tyres

### ACCESSORIES AND OPTIONS

- Diesel scrubber
- Full height spring hinged gates
- Non-marking grip lug foam-filled tyres

\* Capacities, and machine weights may differ when options are added

# SJ9241/50 RT ROUGH TERRAIN SCISSORS

Dimensions	SJ9241 RT	SJ9250 RT
<b>A</b> Work Height	14.50 m	17.24 m
<b>B</b> Raised Platform Height	12.50 m	15.24 m
<b>C</b> Lowered Platform Height	1.68 m	2.01 m
<b>D</b> Overall Width	2.34 m	2.34 m
<b>E</b> Overall Length	4.47 m	4.47 m
<b>F</b> Stowed Height (Rails Up)	2.84 m	3.16 m
<b>G</b> Stowed Height (Rails Down)	1.98 m	2.29 m
<b>H</b> Platform Width (Inside Dimension)	1.88 m	1.88 m
<b>I</b> Platform Length Stowed (Inside Dimension)	7.21 m	7.21 m

Specifications	SJ9241 RT	SJ9250 RT
Ground Clearance	0.20 m	0.20 m
Wheelbase	3.02 m	3.02 m
Weight	6,715 kg	7,407 kg
Gradeability	25%	25%
Turning Radius (Inside)	5.33 m	5.33 m
Turning Radius (Outside)	7.65 m	7.65 m
Lift Time (With Rated Load)	62 sec	64 sec
Drive Speed (Stowed)	3.8 km/h	3.8 km/h
Drive Speed (Raised)	0.72 km/h	0.72 km/h
Maximum Drive Height	Full Height	9.14 m
Capacity (Overall)	681 kg	681 kg
Maximum # of Persons	5	5

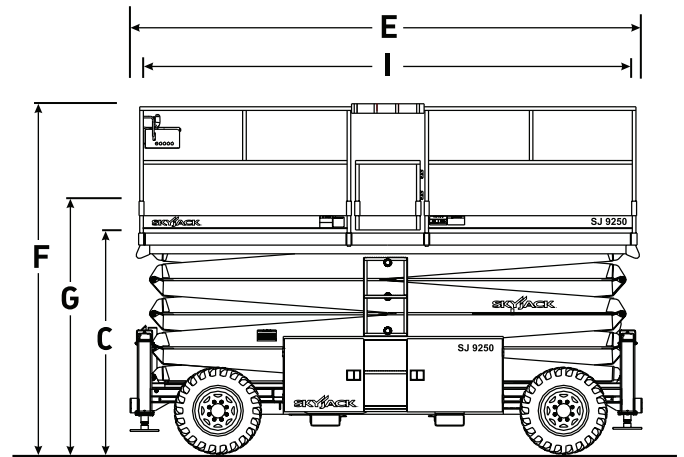
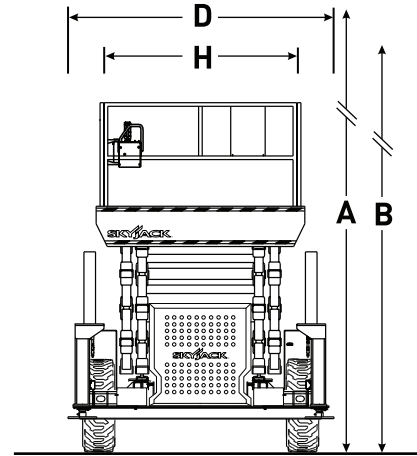

Model	Capacity With 2 Extension Decks*		
	Main	Front Ext.	Rear Ext.
SJ9241 RT	227 kg	227 kg	227 kg
SJ9250 RT	227 kg	227 kg	227 kg

\* With standard tyres